



WHITEBRAIND

*Feel the
Space*

Whitebraind supporta i brand che mettono al centro del loro modello di business il cliente e la sua esperienza.

La customer centricity per essere efficace necessita di una relazione brand - essere umano ricca di emozioni e ricordi positivi.

Sentire lo spazio, connettersi al brand attraverso i touch point fisici aumenta la possibilità di provare emozioni positive e ingaggianti.

Whitebraind crea concept in grado di offrire alle persone esperienze intense e memorabili che rafforzano il legame con il brand e producono fedeltà. Whitebraind realizza spazi che traducono in forma e immagini il **DNA del brand** favorendo lo sviluppo di coerenza e autenticità.



WHY CUSTOMER EXPERIENCE?

Whitebraind crea concept in grado di offrire alle persone esperienze intense e memorabili che rafforzano il legame con il brand e producono fedeltà. Sentire lo spazio, connettersi al brand attraverso i **touch point** fisici aumenta la possibilità di provare emozioni positive e ingaggianti.

La **customer experience** è il complesso di esperienze vissute dal cliente come risultato della sua interazione con il brand. L'experience deve essere intesa come un evento memorabile che coinvolge gli individui sul piano personale, identificabile attraverso percezioni diverse:

- **sense** (che coinvolge la percezione sensoriale)
- **feel** (che comprende sentimenti ed emozioni)
- **think** (che stimola i processi cognitivi che ci portano a riflettere sulle cose)
- **act** (che sprona il consumatore ad agire, ad assumere determinati comportamenti e stili di vita)
- **relate** (che si focalizza sulle relazioni)

La **customer centricity** per essere efficace necessita di una relazione brand - essere umano ricca di emozioni e ricordi positivi.



MODELLO ERB - CONCEPT DESIGN

(Evolutionistic Relational Branding)

Carrozza et al. , 2018

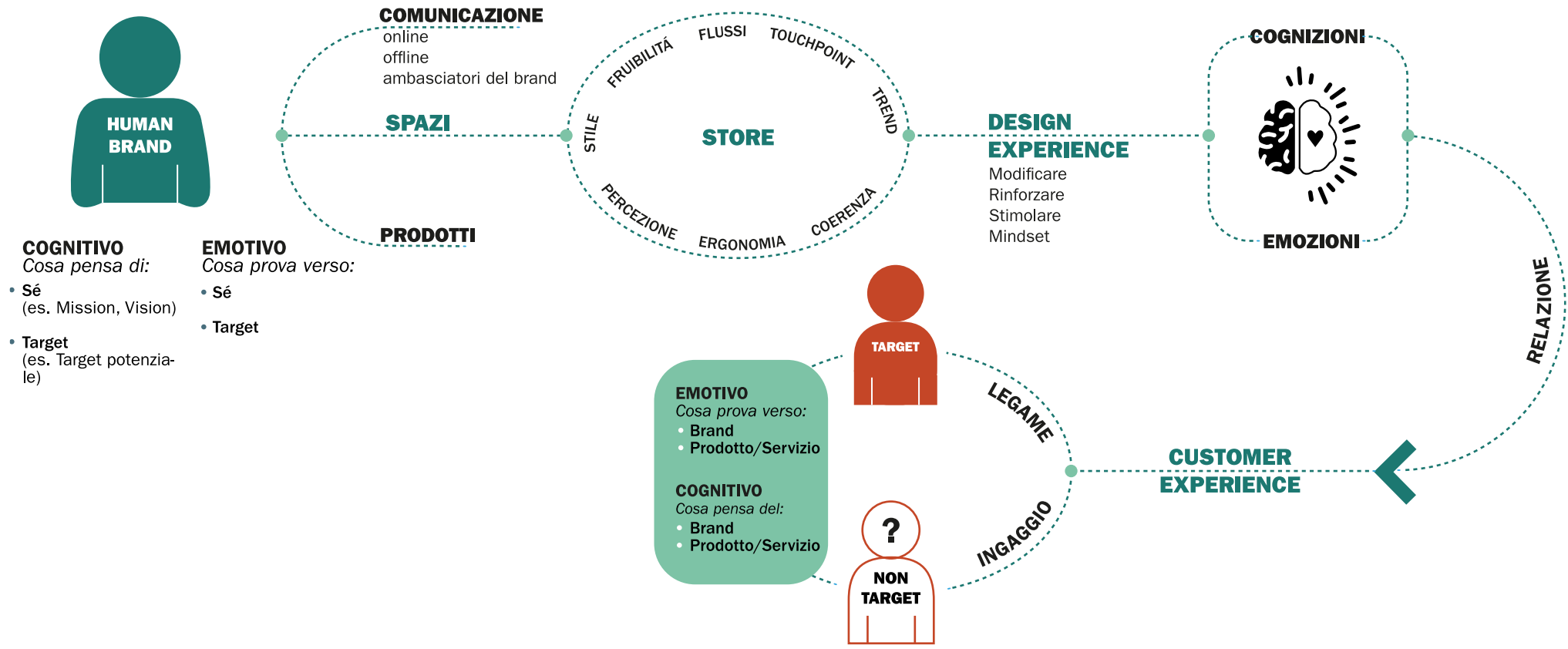

RETAIL CONCEPT DESIGN

Linee guida per la creazione di **spazi retail** finalizzati a rispondere ai gusti in continuo mutamento dei consumatori e a diventare luoghi di vita quotidiana. Spazi che coinvolgono il cliente e lo invitano a creare relazione con il prodotto e a vivere una shopping experience ingaggiante e fidelizzante.



Ride Passion / Pirelli
Madrid

Ride Passion / Pirelli
Assago





Driver / Pirelli
Arese Gomme



Driver / Pirelli
Pneus Marca



P Zero World / Pirelli
Dubai

P Zero World / Pirelli
Montecarlo





P Zero World / Pirelli
Los Angeles



Corner Car / Bridgestone



Corner Olimpico / Bridgestone



Corner Car / Firestone

Corner Agriculture /
Bridgestone - Firestone





Fpt Network Retail Project / Fiat
Amsterdam



P Zero Moda / Pirelli
Berlino



EXHIBITION DESIGN

Linee guida per la creazione di **spazi espositivi** iperconnessi, capaci di comunicare a colpo d'occhio il DNA del brand e migliorare le performance commerciali. Spazi di allestimento che diventano parte integrante del progetto di comunicazione configurandosi non solo come elemento di supporto ma come luoghi iconici del brand, palcoscenico dell'evento.



All Star Aprilia / Piaggio
Circuito del Mugello - Firenze



Autopromotec / Fin Tyre
2016

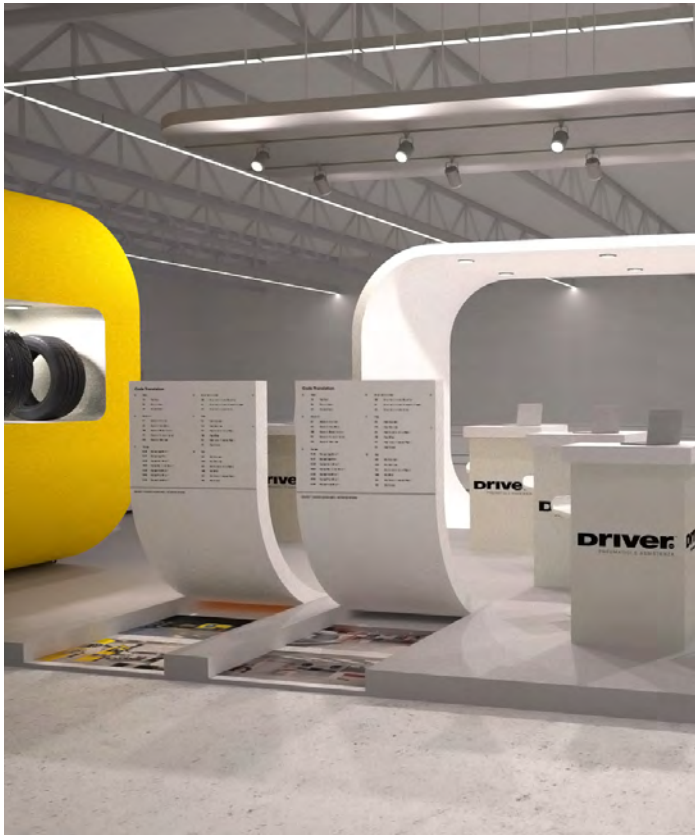

Autopromotec / Driver
2015



Eicma / Metzeler
Milano

HEADQUARTER DESIGN

Linee guida per la creazione di **spazi espositivi** iperconnessi, capaci di comunicare a colpo d'occhio il DNA del brand e migliorare le performance commerciali. Spazi di allestimento che diventano parte integrante del progetto di comunicazione configurandosi non solo come elemento di supporto ma come luoghi iconici del brand, palcoscenico dell'evento.



Motorsport / Pirelli
Milano



EDUTAINMENT DESIGN

Disegnare **percorsi di edutainment** è potenziare l'esperienza emotiva grazie a stimoli capaci di ingaggiare il pubblico attraverso un processo di apprendimento. Whitebraind propone una visione bottom up dove lo spazio evolve e si modifica in base all'analisi dei bisogni dell'utente. L'analisi dei processi cognitivi e di apprendimento è alla base dell'ideazione dei percorsi di visita e del concept. Whitebraind crea linee guida per la creazione di spazi che offrono al brand l'occasione di narrare sé stesso e al visitatore la possibilità di vivere una experience ideata per potenziare il divertimento, l'apprendimento e l'ingaggio.



Fondazione Piaggio
Pontedera





Factory / Pirelli
Slatina

PRODUCT & SERVICE

Linee guida per l'**identificazione delle leve** per potenziare la connessione tra brand e target: il prodotto/servizio diventa elemento di storytelling e narra al consumatore l'essenza del brand. Nascono elementi che ingaggiano, fidelizzano, consolidano l'identità del brand e la percezione del suo valore da parte del consumatore.

PRODUCT REBRANDING

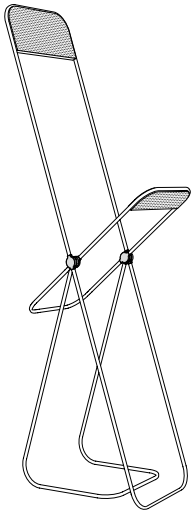

_1 Lampada da terra

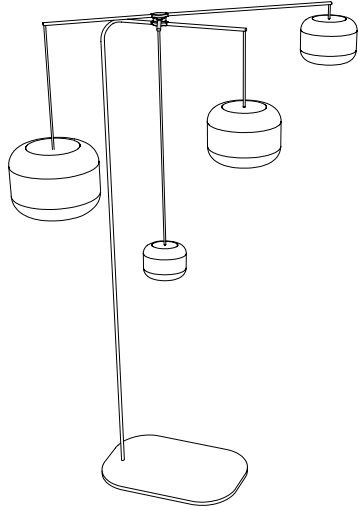

_2 Lampada da terra

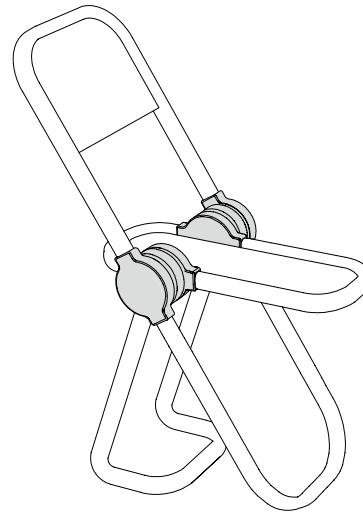

_3 Lampada da tavolo

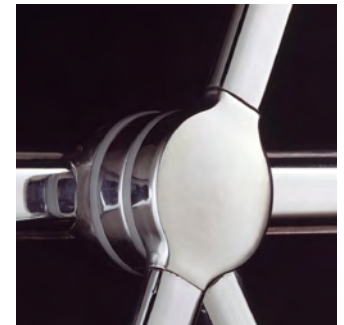

PLIA CHAIR
GIANCARLO PIRETTI

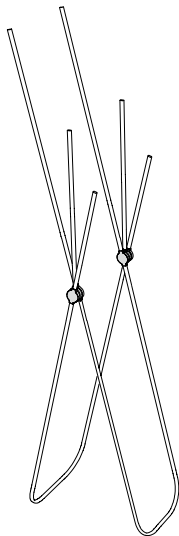

_4 Appendiabiti da terra

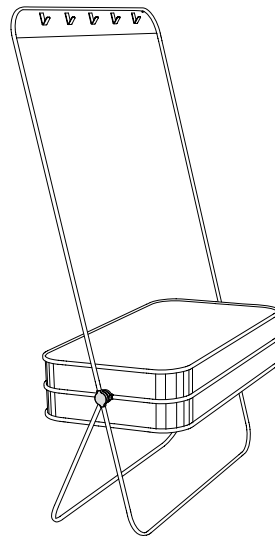

_5 Mobile appendiabiti

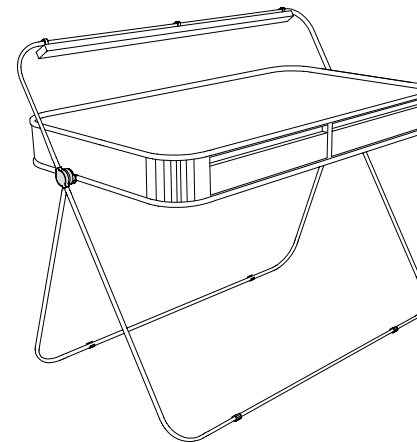

_6 Scrivania

Plia / Castelli
Bologna

CUSTOM FURNITURE



Furniture / Pirelli
2014-2018



MERCHANDISING / PIRELLI

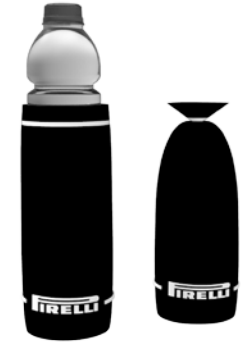
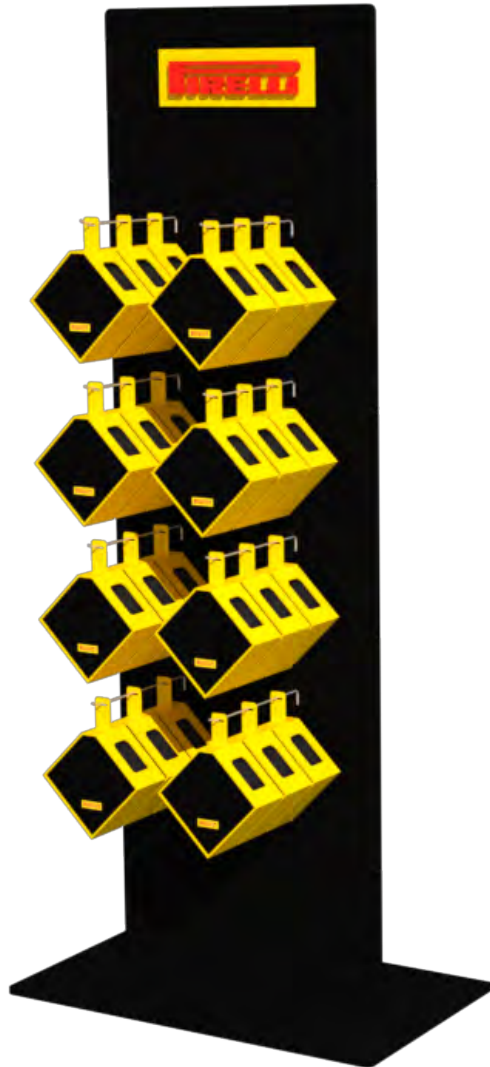

CITY BRANDING

La città è una **creatura pulsante**, con una precisa identità. La metodologia applicata da Whitebraind prevede di utilizzare un osservatorio neutrale capace di elaborare input e suggerire output coerenti all'identità urbana, in grado di ingaggiare nuovi target di visitatori e rafforzare il legame con chi la vive. Whitebraind offre linee guida per la creazione di brand identity, spazi, servizi, in linea con il DNA della città.

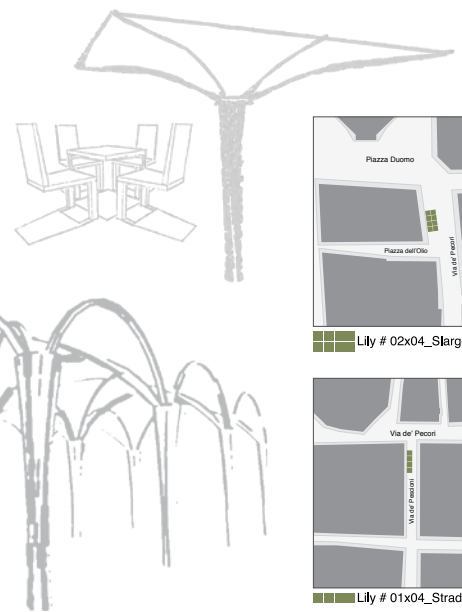
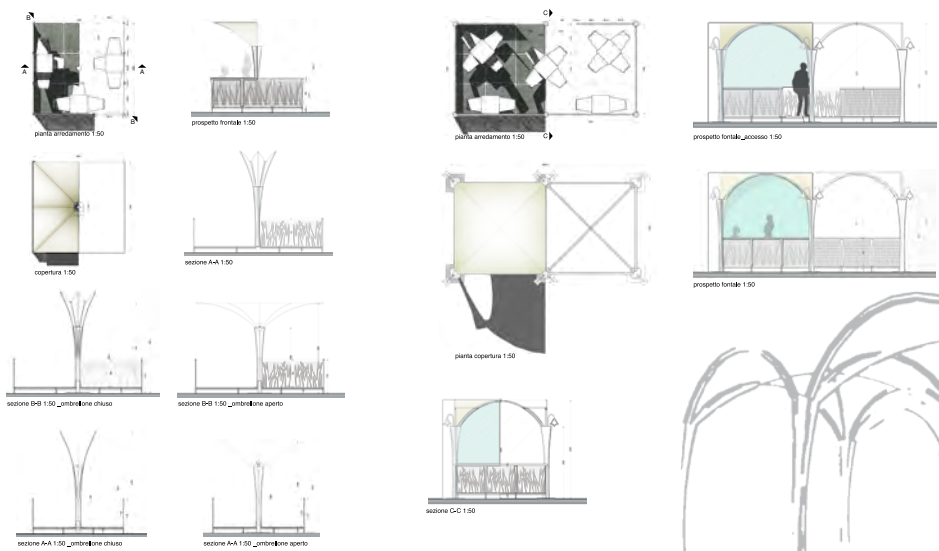

SISTEMI DI AGGREGAZIONE

- Lily
- Lily_02
- Lily_02x02
- Lily_04
- Lily_02x04
- Lily_02x05

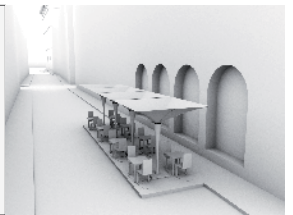
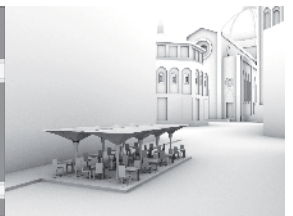

#01 Struttura in acciaio #02 Pedana con struttura in acciaio e investimento in pietra serena #03 Ringhiera in pannello litorali verniciati a polvere bianca #04 Copertura in poliestere tefato impermeabile #05 Chiusura in vetro e policarbonato UV

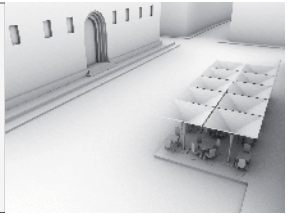
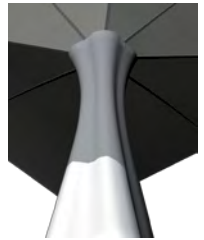
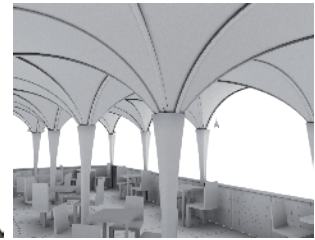
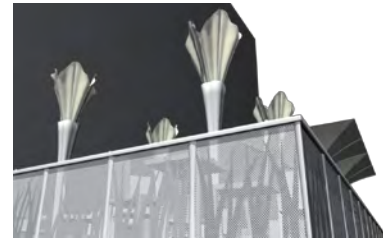

Dehor
Firenze



CLIENTS



FIGRELLA RUBINO





WHITEBRAIND

Via Dei Pandolfini, 27 - 50122 Firenze
www.whitebraind.com
newbusiness@whitebraind.com

Nicola Benedettini

Commercial/new business
T. +39 339 5766220
newbusiness@whitebraind.com

